

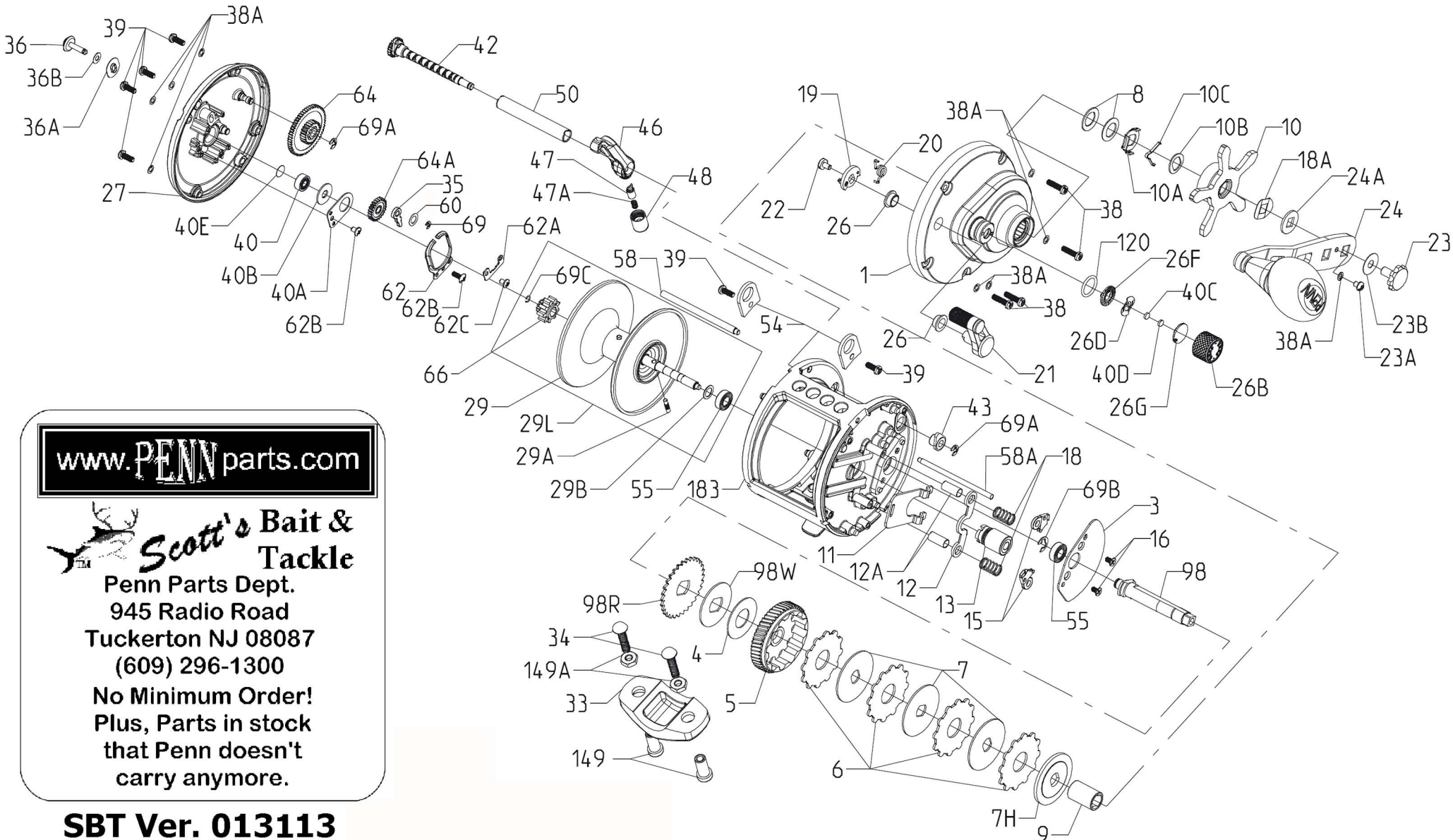

PARTS LIST FOR MODELS FATHOM 40LW



www.PENNparts.com

Scott's Bait & Tackle
Penn Parts Dept.
945 Radio Road
Tuckerton NJ 08087
(609) 296-1300
No Minimum Order!
Plus, Parts in stock
that Penn doesn't
carry anymore.

SBT Ver. 013113
Based on Penn's Rev 1 3/15/10

Penn Reel Parts list for:

KEY	PUREFISHING	PENN PART	
NO	PART #	NO.	DESCRIPTION
1	1208121	1-FTH40LW	RIGHT SIDE PLATE ASSEMBLY
3	1208123	3-FTH40LW	BRIDGE
4	1188703	4-FTH20LW	DRAG WASHER
5	1207786	5-FTH40LW	MAIN GEAR
6	1188705	6-FTH20LW	DRAG WASHER, TABBED HT 100 (4 REQUIRED)
7	1188706	7-FTH20LW	KEYED METAL DRAG WASHER (3 REQUIRED)
7H	1188707	7H-FTH20LW	HEAVY METAL DRAG WASHER
8	1188709	8-FTH20LW	SPRING WASHER (2 REQUIRED)
9	1188708	9-FTH20LW	SPACING SLEEVE
10	1188713	10-FTH20LW	STAR DRAG
10A	1188711	10A-FTH20LW	STAR CLICK RETAINER
10B	1188710	10B-FTH20LW	STAR CLICK WASHER
10C	1188712	10C-525MAG2	STAR CLICK SPRING
11	1208067	11-FTH40LW	ECCENTRIC JACK
12	1188687	12-FTH20LW	PINION YOKE
12A	1208062	12A-FTH20LW	YOKE POST BUSHING (2 REQUIRED)
13	1188683	13-FTH20LW	PINION GEAR
15	1188675	15-FTH20LW	DOG
16	1188676	16-FTH20LW	BRIDGE SCREW (2 REQUIRED)
18	1188677	18-FTH20LW	PINION YOKE SPRING (2 REQUIRED)
18A	1188714	18A-FTH20LW	KEYED SPRING WASHER
19	1188691	19-FTH20LW	ECCENTRIC
20	1188689	20-FTH20LW	ECCENTRIC SPRING
21	1208126	21-FTH40LW	ECCENTRIC LEVER
22	1188690	22-FTH20LW	ECCENTRIC SCREW
23	1208117	23-FTH20LW	HANDLE SCREW
23A	1188717	23A-FTH20LW	HANDLE LOCK SCREW
23B	1207784	23B-FTH20LW	HANDLE SCREW WASHER
24	1188716	24-FTH20LW	HANDLE
24A	1188715	24A-FTH20LW	HANDLE THRUST WASHER
26	1188692	26-FTH20LW	BUSHING (2 REQUIRED)
26B	1208114	26B-FTH20LW	SPOOL TENSION CONTROL CAP
26D	1125769	26D-525MAG2	SPOOL TENSION CLICK SPRING
26F	1125768	26F-525MAG2	SPOOL TENSION RATCHET, INNER
26G	1125772	26G-525MAG2	SPOOL TENSION RATCHET, OUTER
27	1208125	27-FTH40LW	LEFT SIDE PLATE
29	1208127	29-FTH40LW	SPOOL SUB-ASSEMBLY
29A	1188680	29A-FTH20LW	SPOOL SHAFT PIN
29B	1208078	29B-FTH20LW	WASHER
29L	1208128	29L-FTH40LW	SPOOL ASSEMBLY (ALUMINUM)
33	1208077	33-FTH40LW	ROD CLAMP
34	1128058	34-FTH20LW	ROD CLAMP SCREW

Model: FTH40LW FATHOM 40LW

KEY	PUREFISHING	PENN PART	
NO	PART #	NO.	DESCRIPTION
35	1188656	35-FTH20LW	CLICK TONGUE
36	1208124	36-FTH40LW	CLICK BUTTON
36A	1208113	36A-FTH20LW	CLICK WASHER
36B	1188651	36B-FTH20LW	CLICK PVC WASHER
38	1188698	38-FTH20LW	SCREW M3X12 (4 REQUIRED)
38A	1188649	38A-FTH20LW	FLAT WASHER (9 REQUIRED)
39	1188638	39-FTH20LW	SCREW M3X8 (6 REQUIRED)
40	1188661	40-FTH20LW	BALL BARING 4X10X4 (2 REQUIRED)
40A	1188663	40A-FTH20LW	BALL BEARING RETAINER
40B	1188662	40B-FTH20LW	FELT WASHER
40C	1208115	40C-525MAG2	WASHER, METAL THRUST
40D	1125771	40D-525MAG2	WASHER, RUBBER THRUST
40E	1188660	40E-FTH20LW	BRONZE WASHER
42	1208072	42-FTH40LW	WORM SHAFT ASSEMBLY
43	1188669	43-FTH20LW	WORM SHAFT BUSHING
46	1208129	46-FTH40LW	LINE GUIDE ASSEMBLY
47	1188672	47-FTH20LW	LINE GUIDE PAWL
47A	1188673	47A-FTH20LW	LINE GUIDE SPRING
48	1208120	48-FTH20LW	LINE GUIDE NUT
50	1208071	50-FTH40LW	WORM SHEILD
54	1208069	54-FTH40LW	HARNES LUG (2 REQUIRED)
55	1188681	55-FTH20LW	BALL BEARING 6X12X4
58	1208066	58-FTH40LW	SLOTTED LINE GUIDE POST
58A	1208068	58A-FTH40LW	LINE GUIDE GUARD POST
60	1188670	60-FTH20LW	WASHER
62	1188664	62-FTH20LW	CLICK SPRING
62A	1188653	62A-FTH20LW	CLICK SPRING GUARD
62B	1188665	62B-FTH20LW	SCREW M2.6X7.5 (2 REQUIRED)
62C	1188654	62C-FTH20LW	SCREW M26.X4
64	1188658	64-FTH20LW	IDLER GEAR
64A	1208073	64A-FTH20LW	IDLER GEAR
66	1188678	66-FTH20LW	SPOOL GEAR CLICK RATCHET
69	1188657	69-FTH20LW	RETAINER 2X5
69A	1188659	69A-FTH20LW	RETAINER 3X7 (2 REQUIRED)
69B	1208064	69B-FTH40LW	RETAINER 5X10
69C	1188677	69C-FTH20LW	RETAINER "C" RING
98	1207787	98-FTH40LW	MAIN GEAR SHAFT
98R	1188701	98R-FTH20LW	RATCHET
98W	1188702	98W-FTH20LW	RATCHET THRUST WASHER
120	-N/A-	120-FTH15LW	O-RING
149	1128059	149-FTH20LW	ROD CLAMP LONG NUT (2 REQUIRED)
149A	1116161	149A-FTH20LW	HEX NUT (2 REQUIRED)
183	1208122	183-FTH40LW	FRAME

CORRECTIONS:

Original revision listed 120-113H as the O-ring, but this was not correct. Assigned #120-FTH15LW by Pennparts.com

SBT Ver. 013113 (Based on Penn's Rev 1 3/15/10 - w/part # changes from 8/2011)

Revision: Early run reels may contain a small shim between 47 and 47A. This is correcting a slight gap in the early 48 line guide nut, and is not needed on later reels.

NOTE: Many of www.pennparts.com schematics include changes that were either made by Penn, or errors found and corrected by our parts dept.