

349 gear ratio 2.33:1 Master Mariner

(Used 149 Schematic as a template
Not all parts may be exact shapes)

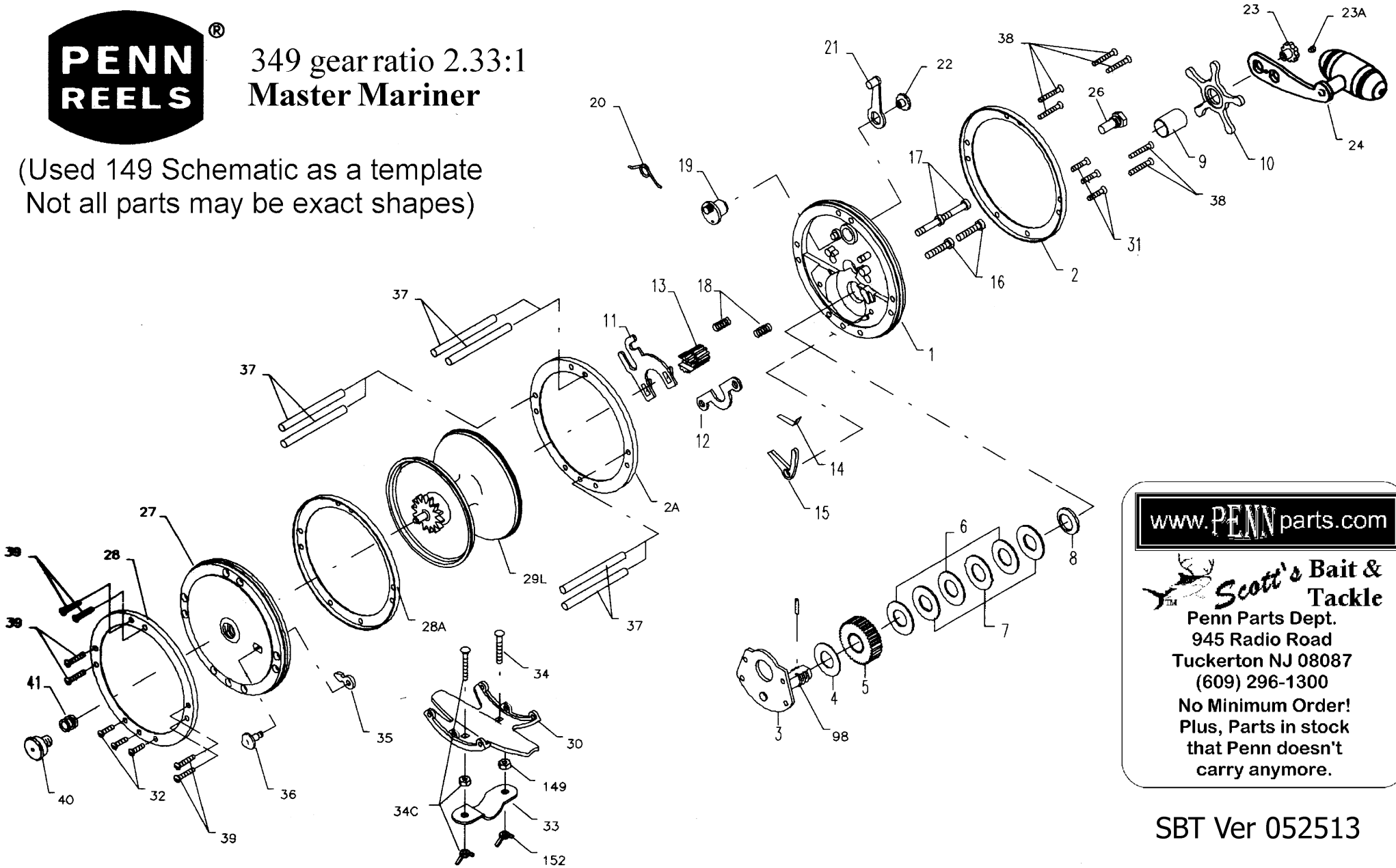

www.PENNparts.com

Scott's Bait & Tackle
Penn Parts Dept.
945 Radio Road
Tuckerton NJ 08087
(609) 296-1300
No Minimum Order!
Plus, Parts in stock
that Penn doesn't
carry anymore.

SBT Ver 052513

Penn Reel Parts list for Model 349 Master Mariner

2.33:1 gear ratio

KEYPART			KEYPART		
NONO.	DESCRIPTION		NONO.	DESCRIPTION	
1	1-349	R.S. PLATE	21	21-49	ECCENTRIC LEVER
2	2-349	R.S. RING	22	22-60CH	ECCENTRIC SCREW
3	3-349	BRIDGE W/ SLEEVE	23	23-114	HANDLE SCREW
4	4-349	FIBER WASHER	23A	110-60	HANDLE LOCK SCREW
5	5-349	MAIN GEAR	24	24-349	COMPLETE HANDLE
6	6-349	DRAG WASHER	26	26-349	R.S BEARING
7	7-349	METAL DISC SET	27	27-349	L.S. PLATE
8	8-349	TENSION SPRING	28	28-349	L.S. RING
9	9-349	SPACING SLEEVE	29M	29M-349	METAL SPOOL
10	10-349	STAR DRAG	30	30-349	STAND
11	11-349	ECCENTRIC JACK	31 + 32	32-18	STAND SCREWS (6 REQUIRED)
12	12-349	PINION YOKE	33	33-49	ROD CLAMP
13	13-349	PINION GEAR	34	34C-49	CLAMP SCREW W/ NUTS
14	14-349	DOG SPRING	35	35-114	CLICK TONGUE
15	15-349	DOG	36	36-114H	CLICK BUTTON
16	16-60CH	LOWER BRIDGE SCREW	37	37-49	FRAME POST
17	17-60CH	UPPER BRIDGE SCREW	38 + 39	39-9	POST SCREWS (12 REQUIRED)
18	18-349	CLUTCH SPRING	40	40-349	L.S. BEARING
19	19-60	ECCENTRIC	41	41-349	L.S. BEARING SPRING
20	20-60L	ECCENTRIC SPRING	98	98-349	BRIDGE SLEEVE

NOTE: Many of www.pennparts.com schematics include changes that were either made by Penn, or errors found and corrected by our parts dept.
SBT Ver. 052513