

www.PENNparts.com

Scott's Bait & Tackle

Penn Parts Dept.  
945 Radio Road  
Tuckerton NJ 08087  
(609) 296-1300

No Minimum Order!  
Plus, Parts in stock  
that Penn doesn't  
carry anymore.

SBT Ver. 090713



## Penn Reel Schematic 112 3/0 Senator

Using a 112H schematic and 112 reel  
built 11/20/03

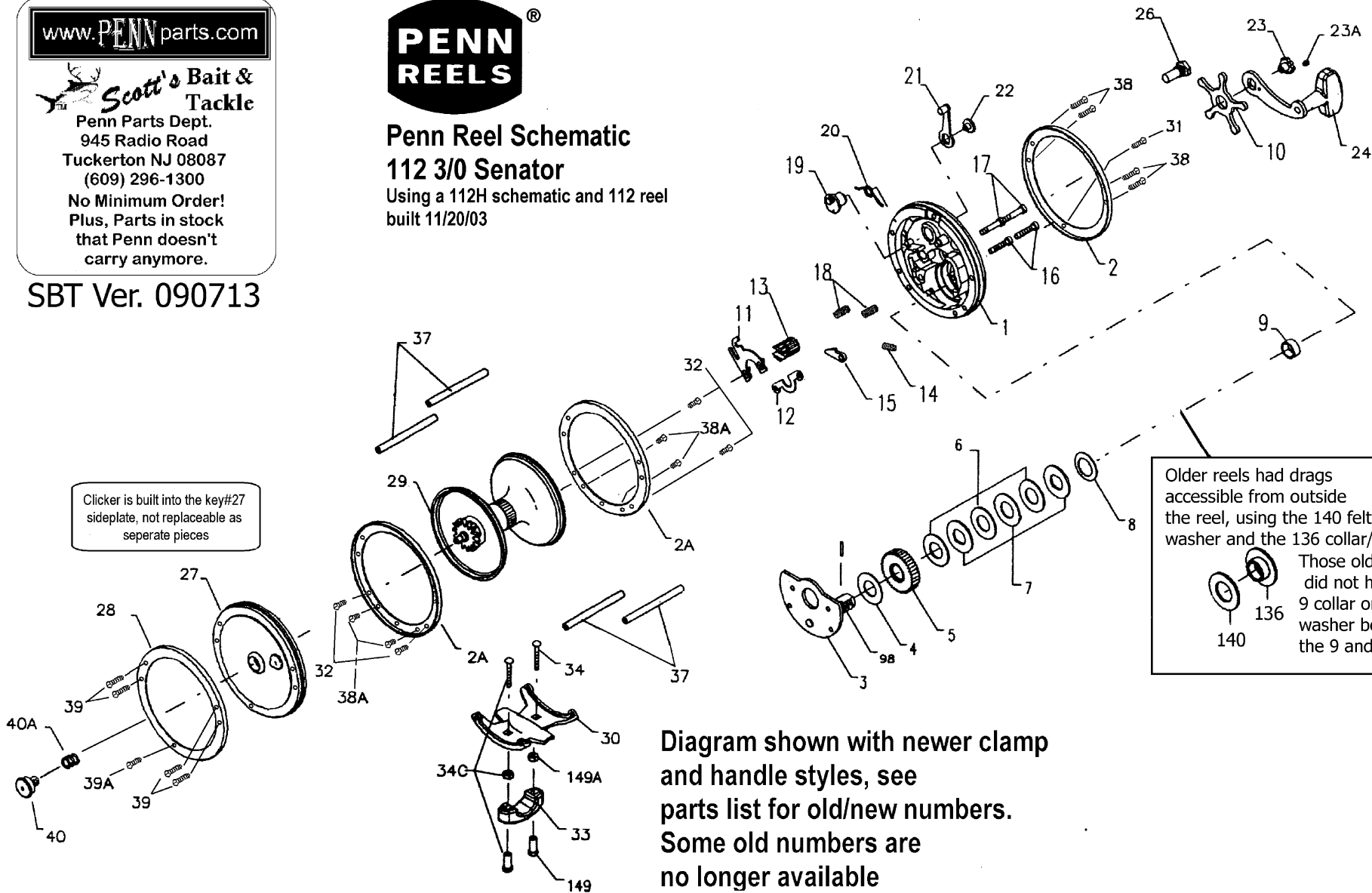

## Penn Reel Parts list for Model: 112 3/0 Senator

KEY NO	PART NO.	DESCRIPTION	KEY NO	PART NO.	DESCRIPTION
1	1-112	HANDLE SIDE PLATE	24	24-155	HANDLE
2	2-111-O	OUTER HANDLE SIDE RING	26	26-60	HANDLE SIDE BEARING
2A	2-111-I	INNER RING (2 REQUIRED)	27	27-111	NON-HANDLE SIDE PLATE w/clicker
3	3-66	BRIDGE W/ SLEEVE	28	2-111-O	OUTER NON-HANDLE SIDE RING
4	4-60	FIBER WASHER	29	29M-112	SPOOL
5	5-66	MAIN GEAR	30	30-112	STAND
6	6-113	DRAG WASHER (3 REQUIRED)	31	39-3	HANDLE SIDE OUTER STAND SCREW (1)
7	7C-60	METAL DRAG WASHER SET (3 REQUIRED)	32	32-15	INNER STAND SCREWS, BOTH SIDES (4 REQUIRED)
8	8-60	TENSION SPRING	33	33-200	ROD CLAMP (ORIG. METAL)
9	9-66	SPACING SLEEVE		33-113	ROD CLAMP (PLASTIC)
10	10-60	STAR DRAG WHEEL	34	34-200	CLAMP SCREW (2 REQUIRED)
11	11-60	ECCENTRIC JACK	34C	34C-200	ROD CLAMP SCREW W/ NUTS (for metal)
12	12-60	PINION YOKE		34C-45	ROD CLAMP SCREW W/ NUTS (for plastic)
13	13-49	PINION	37	37-113	FRAME POST (6 REQUIRED)
14	14-99	DOG SPRING	38	39-9	HANDLE SIDE POST SCREW (4 REQUIRED)
15	15-99	DOG	38A	39-10	INNER R/L POST SCREW (8 REQUIRED)
16	16-60CH	LOWER BRIDGE SCREW (2 REQUIRED)	39	39-3	NON-HANDLE SIDE POST SCREW (4 REQUIRED)
17	17-60CH	UPPER BRIDGE SCREW (2 REQUIRED)	39A	32-17	NON-HANDLE SIDE OUTER STAND SCREW (1)
18	18-60	CLUTCH SPRING (2 REQUIRED)	40	40-60	NON-HANDLE SIDE BEARING
19	19-250	ECCENTRIC	41	41-60	NON-HANDLE SIDE BEARING SPRING
20	20-60L	ECCENTRIC SPRING	98	98-60	GEAR SLEEVE
21	21-66	ECCENTRIC LEVER	149	149-45	ROD CLAMP NUT (2 REQUIRED)
22	22-99	ECCENTRIC SCREW	149A	149-200	LOWER BRIDGE SCREW (2 REQUIRED)
23	23-60	HANDLE SCREW			
23A	110-60	HANDLE LOCK SCREW			

NOTE: Many of [www.pennparts.com](http://www.pennparts.com) schematics include changes that were either made by Penn, or errors found and corrected by our parts dept.

SBT Ver 101213

NOTE: These parts were used on the old models where the drag washers were accessible from the outside:

The parts are not available, they are just listed for reference

1-112old Handle Side Plate with outside drag access

140-112 Felt Washer

136-112 Pressure Plate Washer